

Vibration batch dryer WS-R-V-CT

For drying small to medium batches of materials



Vibration batch dryer WS-R-V-CT For drying small to medium batches of materials

The Allgaier vibration batch dryer is used for drying solid materials which are difficult to handle and is particularly suitable for products which

- initially tend to stick together or are difficult to fluidise,
- have an irregular grain shape and a wide range of grain sizes,
- change their properties during drying,
- require long drying times,
- must be handled very carefully because of their sensitivity.

Advantages of the Allgaier batch dryer:

- The integrated agitator and the vibration system support fluidisation of the product and prevent it from sticking to the side walls.
- The dryer hood can be opened easily for filling, removal of samples, inspection and cleaning.
- An automatic, pneumatic emptying system simplifies handling of the product.
- The dryer is easily installed, even where there is little space or in rooms with low ceilings.

With this vibration batch dryer with integrated agitator, Allgaier has developed a very efficient technology which is particularly suitable for drying small to medium batches of wet solid. The dryer

is designed so that it can handle widely varying amounts of solid materials.

The dryer is designed so that it can be installed even in rooms with low ceilings, such as laboratory rooms. It can thus be used for many tasks in research and product development and for the production of small to medium quantities.

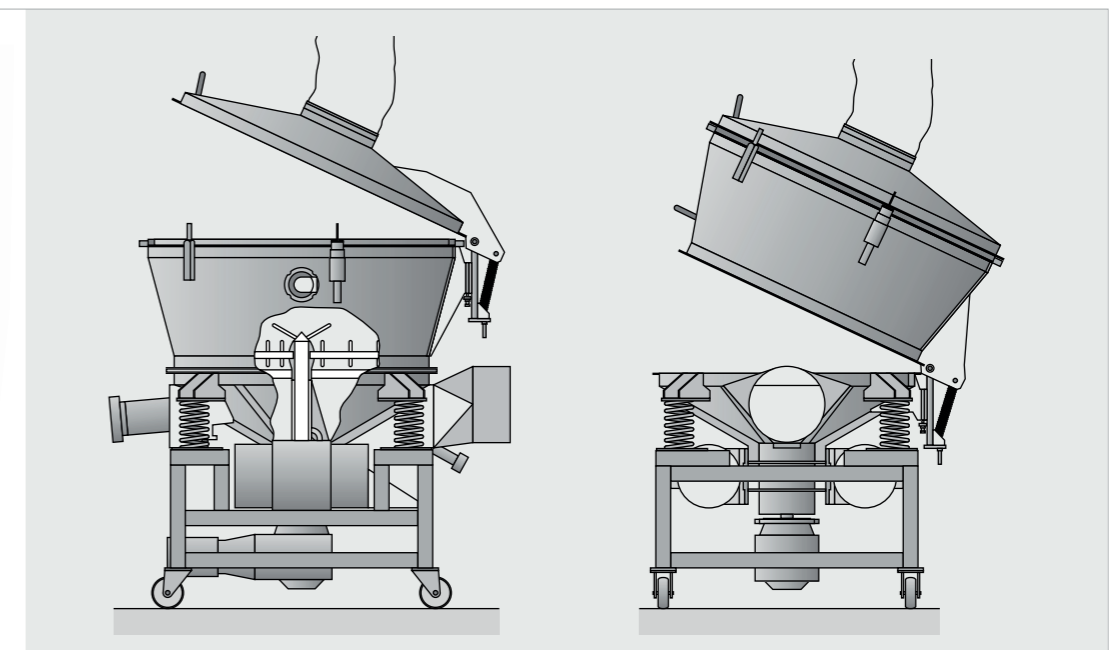

The round tank has a capacity of between 20 and 80 litres and the dryer can thus be used for the production of representative product quantities at low investment cost.

In order to permit the use of the dryer in foodstuffs production or in various pharmaceutical applications, it is designed for very easy cleaning

and maintenance. Both the air-director plate and the retaining sieve located in the upper part of the dryer can be removed very quickly by means of a hinged mechanism. These parts are held in position with quick-acting clamps.

ALLGAIER Process Technology GmbH

Ulmer Straße 45
73066 Uhingen
Germany
Telefon: +49 7161 301-175
Telefax: +49 7161 34268
process-technology@allgaier-group.com

