

Fluidized Bed Technology

High-performance fluidized bed dryers with integrated heating surfaces

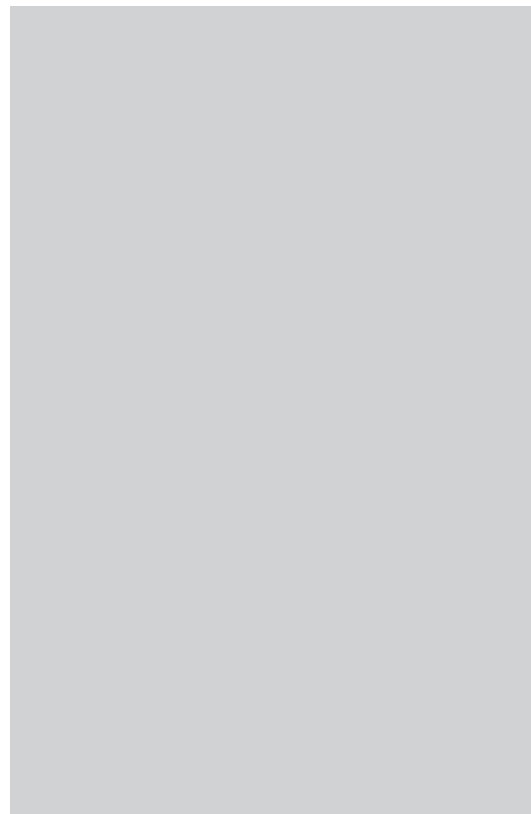
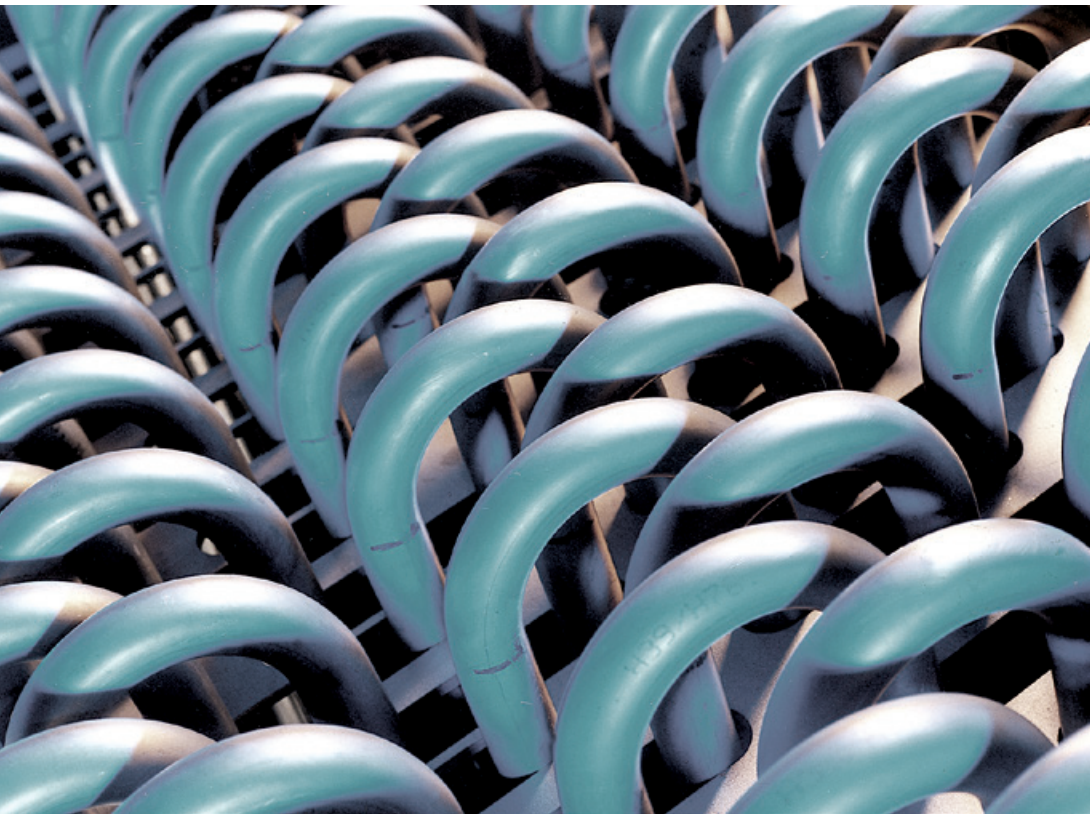

Optimized efficiency due to integrated heating surfaces

Fluidized bed technology is frequently used for the drying and cooling of bulk materials due to optimal conditions for heat and mass transfer.

However, the drying performance cannot be further enhanced with a higher drying air temperature in cases where only heating sources with a fixed temperature level are available, such as saturated steam or thermal oil. Heat-sensitive products also prohibit an increase in the drying air temperature.

The key is to provide a continuous supply of heat energy within the fluidized bed by means of integrated tubular heat exchangers.

Product benefits

Thus the fluidizing gas is not the sole heat-transfer medium. Up to 80% of the necessary thermal energy is provided indirectly via the heating coils. The hot air required is significantly reduced and the thermal demand, electrical energy consumption and exhaust air heat losses are also reduced. Additionally, the resulting high exhaust air moisture load optimizes the drying process.

The excellent heat transfer and water evaporation rates reduce the dryer size to a minimum. Furthermore, the air inlet and exhaust air components can be designed to have a small form factor.

In order to integrate as much heat transfer area into the bed as possible, fluidized bed heights of up to two meters are common.

Process technology which needs far less drying air

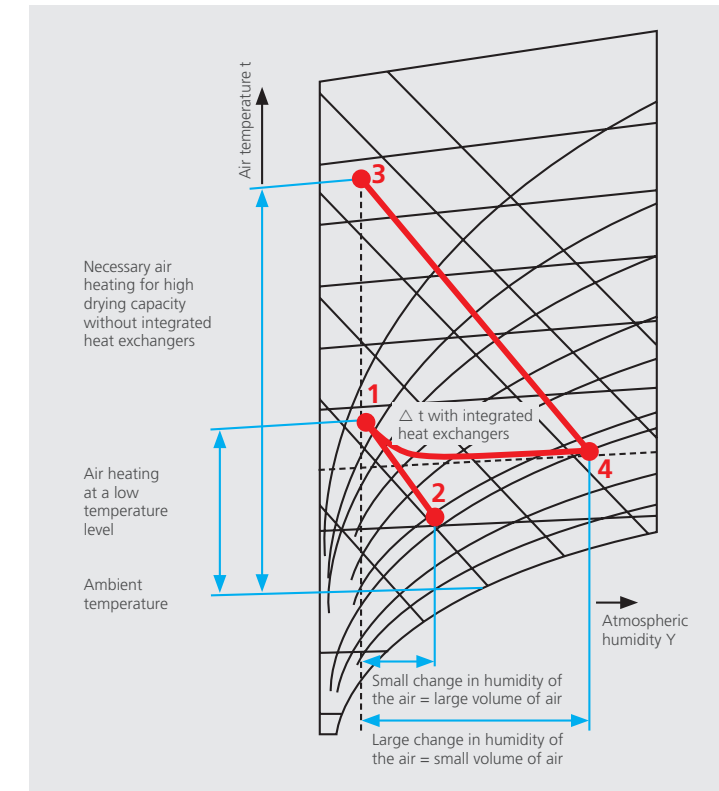

The convective drying process is illustrated in the Mollier diagram to the left, with a low temperature level of the drying air by the change of state from 1 -> 2. Only changes in the humidity necessitates larger volumes of air to evaporate a given volume of water.

Thanks to the additional installation of heat exchanger surfaces, heat is continuously supplied to the bed so that a change of state from 1 -> 4 is possible with a far higher exhaust air enthalpy. The significantly higher water load of the exhaust air requires smaller volumes of air.

In order to achieve a change in water load from 1 to 4 by using only hot air, a significantly higher air inlet temperature level (point 3) would be necessary. However, this is process-related, and may not be possible.

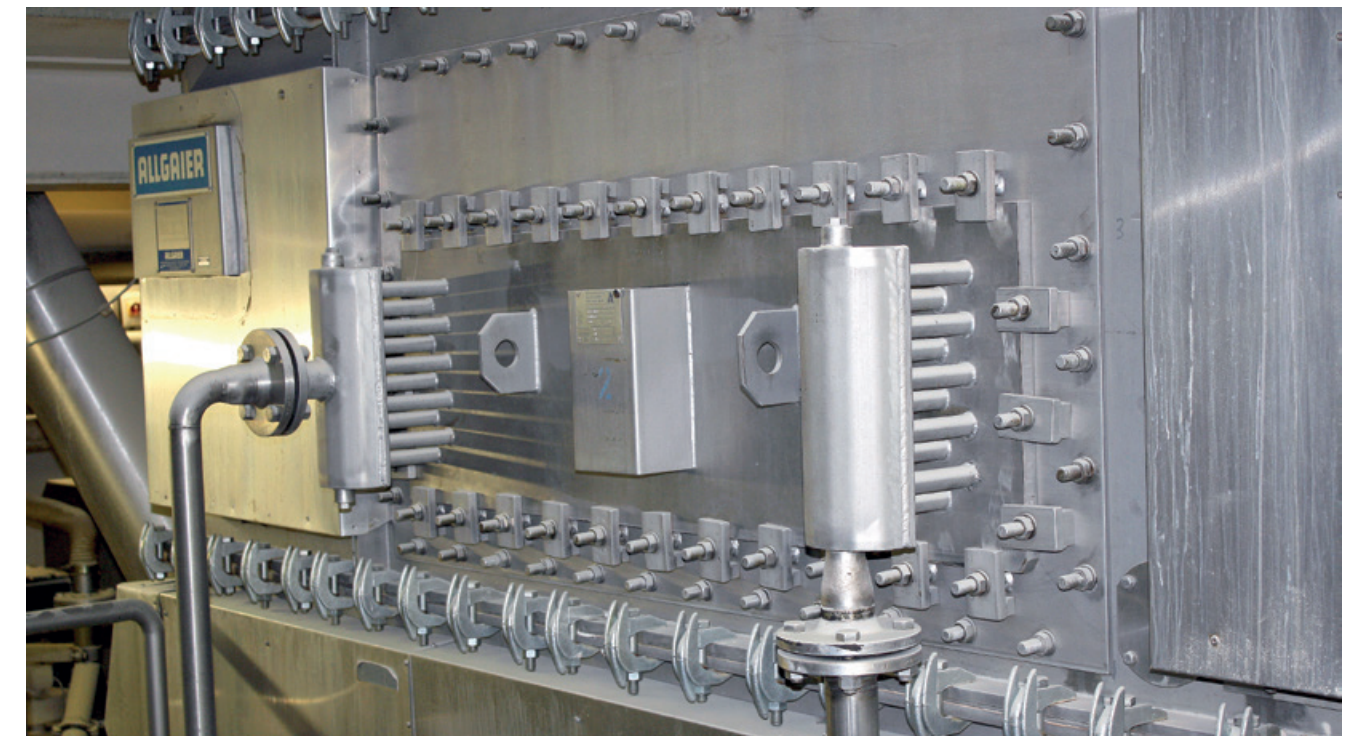

Tubular heat exchanger installed in fluidized bed dryer

Drying and cooling of bulk materials in the fluid bed dryer with immersed tube bundle heat exchangers

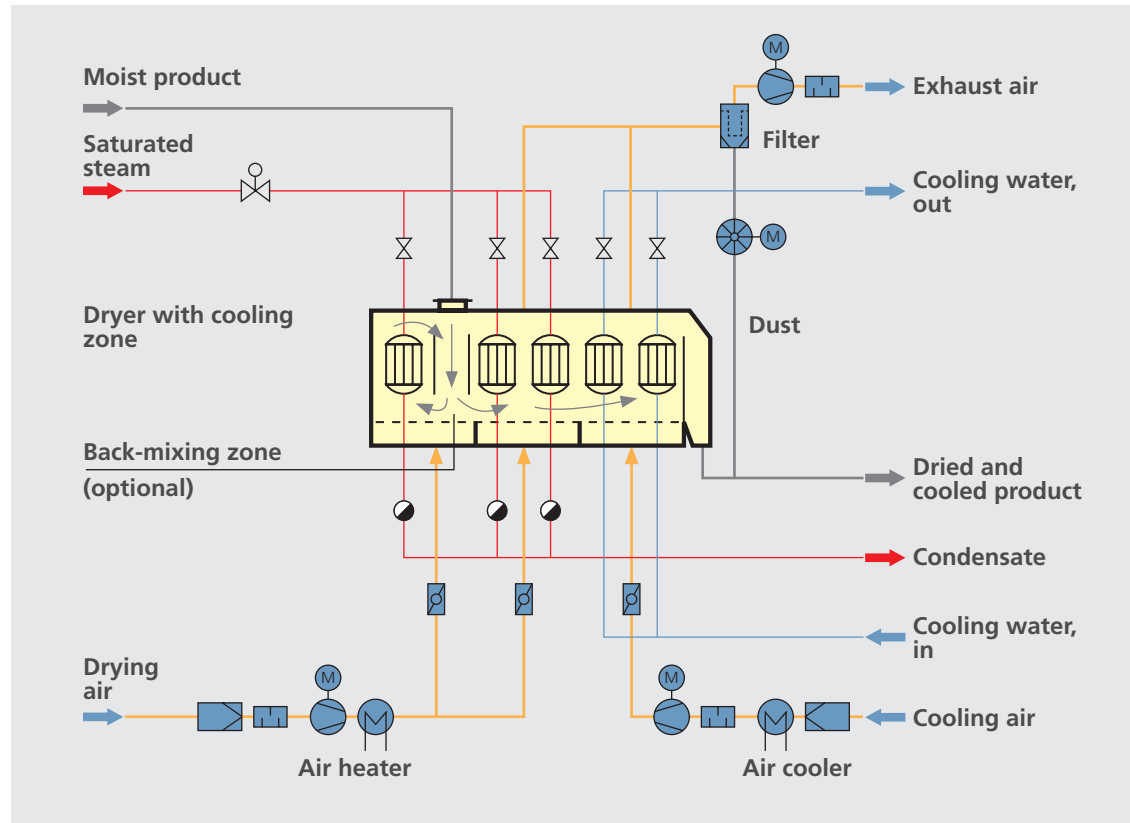

The integration of the heating or cooling surfaces into the fluidized bed optimizes the heat input or heat discharge. Heat transfer sources are steam, hot water or thermal oil. Cooling is effected with cold

water or brine. Allgaier supplies customized solutions tailored to the demands of the particular application, including complete engineering.



Key technology points

Wide choice of materials

Fluid bed dryers with heat exchangers can be constructed from a variety of materials, depending on the corrosive, thermal or mechanical demands of the application.

Design features for cost-effective drying processes

- Suitable for particularly tough environments
- Effective drying of products with high surface moisture content
- Coarse material discharge to prevent accumulation of lumps in the dryer
- Dust discharge via filter systems or cyclones and exhaust air scrubbers

Variable process engineering

Take advantage of Allgaier's vast process know-how for customized solutions.

- Pure drying or drying with subsequent cooling zone
- Single or multi-stage plants
- Combination of different dryer types
- Possibility of heat recovery from the exhaust air
- Heating by all commonly available fuels and heat sources
- Pressure relief and explosion protection
- Integration into process control systems

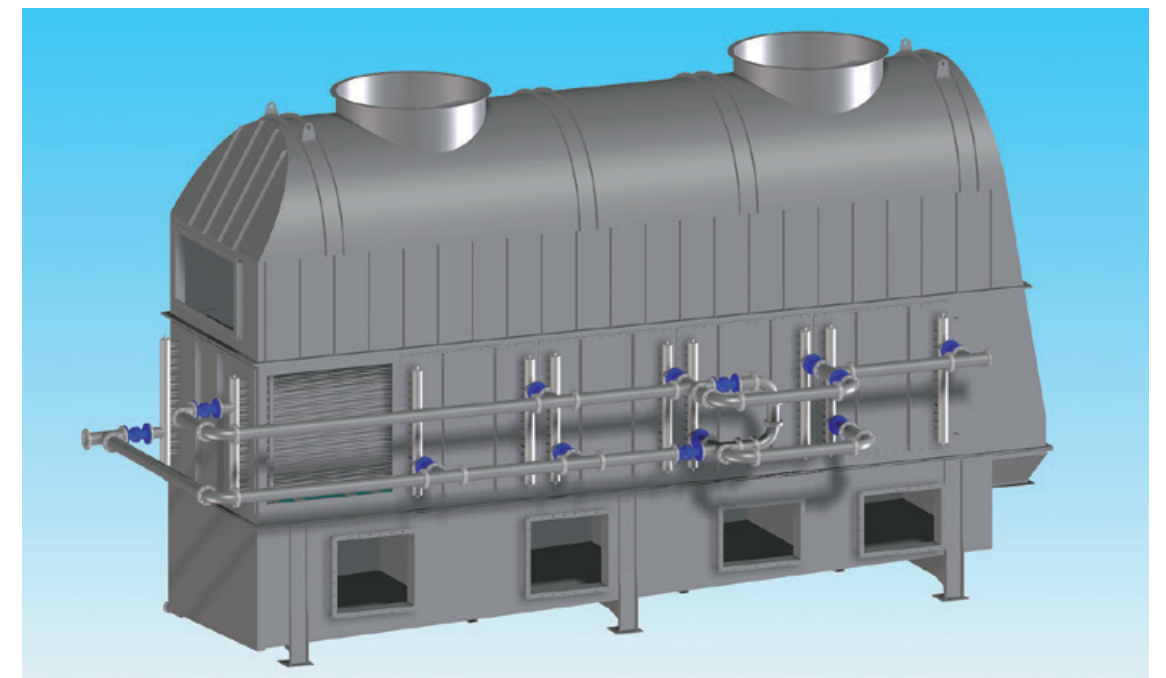

Modern fluidized bed technology safeguards your competitiveness

Our technology makes your products look good.

The benefits of the Allgaier fluidized bed technology can be used in all areas for the drying or cooling of crystalline or granulated bulk materials.

Foodstuffs industry

- Common salt
- Potato granulate
- Sugar
- Conditioning of oilseeds
- Soya

Chemical industry

- Soda
- Sodium sulphate
- Zeoliths
- Activated charcoal cooling
- Iron sulphate
- Plastic powders
- Potassium chloride
- Borax
- Fertilizer cooling
- Ammonium sulphate
- Monoammonium phosphate

Other applications include environmental engineering, agriculture, the minerals industry, metallurgy and the animal feeds industry.

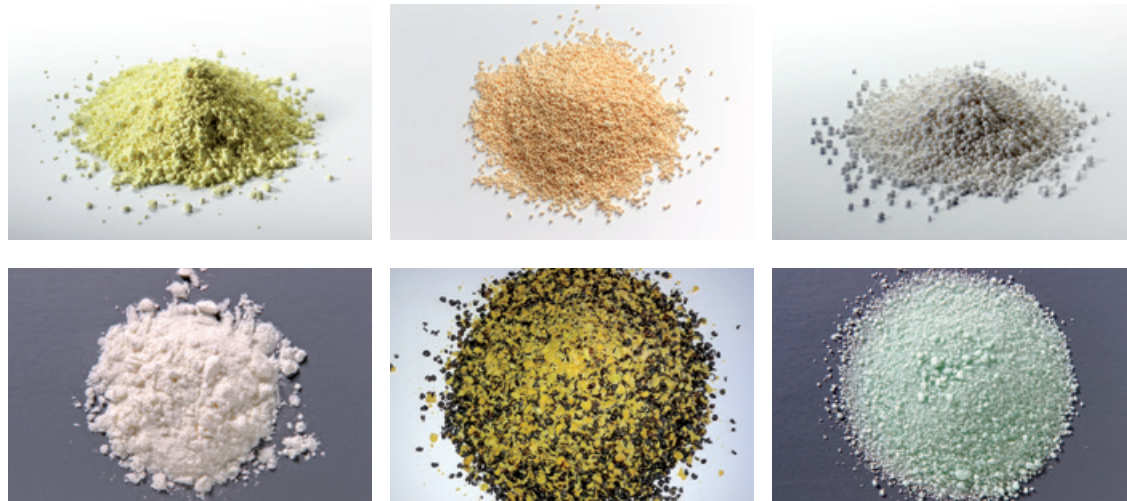

Visit us for a drying trial in our test center

We invite you to see for yourself the quality of the Allgaier fluidized bed dryer with heat exchangers in our test center. This will enable you to not only test the performance of the dryer with your product, but we can also assist you in the product development and sample production.

Our product and process know-how are gained from multiple applications – this means we can provide optimum solutions. We look forward to seeing you in our test center.

The laboratory fluid bed dryer with immersed tube coils can be used for both batch-fed and continuous tests. During the tests, important process parameters are gained that enable a safe scale-up.



Pilot plant at Allgaier test center

ALLGAIER Process Technology GmbH

Ulmer Straße 45
73066 Uhingen
Germany
Telefon: +49 7161 301-175
Telefax: +49 7161 34268
process-technology@allgaier-group.com

